

Press Release

S-1142 CMOS High Input 50V Voltage Regulator Production started in July First shipments in October

July - 2009 - Seiko Instruments Inc. has approved its new High Input Voltage CMOS LDO Voltage Regulator S-1142 for mass production. This Voltage Regulator has an input Voltage of 3V...50V (absolute max. 60V) and a low current consumption of only 4µA typ. (9µA max.). This makes the long awaited voltage regulator the ideal solution for automotive (H: Ta= -40°C...+105°C) applications, where it connects directly to the vehicle battery. It also fits in the consumer version (I: Ta= -40°C...+85°C) perfectly to many multi-cell battery applications for shop, garage, home and garden. The output voltages may be selected from 2.0V to 12.0V in 0.1V increments. With an input to output voltage difference of 2V the regulator is capable of 200mA



(min.) output current, provided that power dissipation is taken care of. Power dissipation of this high performance part is determined by the used package. The applied HSOP-6 (5.02mm x 6.0mm x 1.75mm) package permits up to 1900mW when mounted on a PCB of 50mm x 50mm x 1.6mm, similar to the one specified under Absolute Maximum Ratings. Two kinds of temperature specifications should be considered with this part. One is the ambient temperature Ta which is determined by the components environmental temperature and the junction Temperature Tj which is the temperature in the ICs active semiconductor area. This is the temperature increase that is mainly produced from the power conversion caused by the operating current and the

current through the channel resistance of the power transistor, added to the ambient temperature Ta. Therefore Ta specs determine in which environment this component may be used and Tj has influence on the power capabilities and the specs under operating conditions. Current consumption,

temperature aspects and reliability indicate a superiority of CMOS over bipolar solutions in the high input voltage regulator range. This CMOS IC, as a unipolar semiconductor, has an advantage for physical reasons in that it cannot run into thermal- or 2nd-breakdown, as it is known for bipolar devices with excessive junction temperatures Tj. Instead of thermal self destruction, it will apply a resistive self protection mode. Still a Low-Drop-Out (LDO) is guaranteed by the low on-resistance of the series-regulator transistor which is also utilized in the over-current-protection, the thermal shutdown under overload condition and the ON/OFF control. The over-current-protection will be set in action when the output current exceeds 80mA typ., it is for protection purposes only and not suited to be used as an operational current limit. Thermal shutdown is set for deactivating the output transistor when the junction temperature reaches Tj = 150°C, the release of the shutdown occurs at Tj = 125°C. The ON/OFF control is one more way to increase battery life time by reducing the low operating current from only 4µA typ. to 0.1µA typ. (9.0µA max. to 1.0µA max.) standby current. The phase compensation circuit

Rev.1.0_01

**HIGH-WITHSTAND VOLTAGE LOW CONSUMPTION
CURRENT LOW DROPOUT CMOS VOLTAGE REGULATOR S-1142 Series**

The S-1142 Series, developed based on high-withstand voltage CMOS process, is a positive voltage regulator with a high-withstand voltage, low current consumption, and high output voltage accuracy. The S-1142 Series operates at a high maximum operating voltage of 50 V and a low current consumption of 4.0 µA (typ.). In addition to a built-in low on-resistance transistor which provides a very small dropout voltage and a large output current, the voltage regulator also has a built-in power-off circuit.

An overcurrent protector prevents the load current from exceeding the capacitance of the output transistor. A built-in thermal shutdown circuit prevents damage caused by heat.

A high heat radiation HSOP-6 package enables high-density mounting.

■ Features

- Output voltage : 2.0 V to 12.0 V, selectable in 0.1 V step
- Low equivalent series resistance capacitor : Ceramic capacitor of 0.1 µF or more can be used as the I/O capacitor. 3.0 V to 50 V
- High-accuracy output voltage : ±1.0% (at Tj = +25°C), ±3.0% (Tj = -40°C to +105°C)
- Low current consumption : During operation: 4.0 µA typ., 9.0 µA max. (Tj = -40°C to +105°C)
During shutdown: 0.1 µA typ., 1.0 µA max. (Tj = -40°C to +105°C)
- Output current : 200 mA (at V_{IN} ≥ V_{OUT} + 2.0 V)*
- Built-in overcurrent protector : limits overcurrent of output transistor
- Operation temperature range : -40°C to +105°C (S-1142xxxH only)
- Built-in thermal shutdown circuit : prevents damage caused by heat
- Built-in power on/off circuit : longer battery life
- Small package : HSOP-6
- Lead-free product

*1. Attention should be paid to the power dissipation of the package when the output current is large.

■ Applications

- Constant-voltage power supply for electrical applications for vehicle interiors (S-1142xxxH only)
- Constant-voltage power supplies for home electric appliances

■ Package

Package Name	Drawing Code			
	Package	Tap	Reel	Lead
HSOP-6	FH06-A	FH06-A	FH06-A	FH06-A

Caution: Before using this product in medical equipment or automobile equipment including car audio, keyless entry and engine control unit, contact to SII is indispensable.

Seiko Instruments Inc. 1

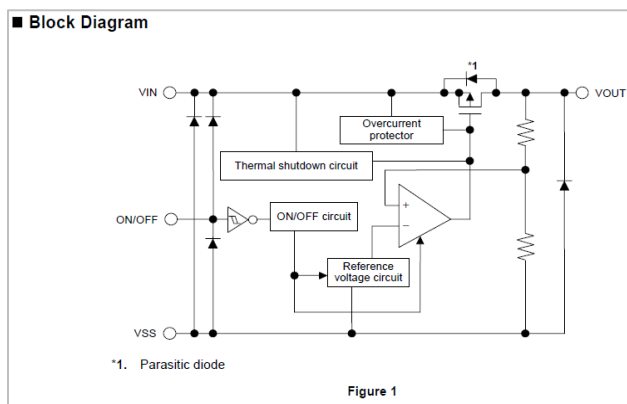

permits low equivalent series resistance ceramic capacitors of 0.1 μ F or more to be used as input and output capacitors. The accuracy of the output voltage at $T_j = +25^\circ\text{C}$ is $\pm 1.0\%$, over the full temperature range of $T_j = -40^\circ\text{C}$ to $+105^\circ\text{C}$ $\pm 3.0\%$ can be specified.

The initial sample supply will be prepared in the industrial "I" temperature range ($T_a = -40^\circ\text{C} \dots +85^\circ\text{C}$) for 3.0V, 3.3V and 5.0V output voltage with either positive or negative ON/OFF logic level, and in the high "H" temperature range for automotive applications for 3.3V and 5.0V output voltage with either positive or negative ON/OFF logic level. Other output voltages can be made on request but will require longer lead time.

Applications:

Automotive applications and included comfort and entertainment systems (S-1142xxxxH)
Battery driven tools and appliances in shop, garage, home and garden

Samples:

Available via your regional Seiko Instruments representative

Contact:

Paul Krisam, Technical Sales Support Manager, Components Department
Seiko Instruments GmbH, Siemensstrasse 9, 63263 Neu-Isenburg
Tel.: +49 6102 297143
eMail : Paul.Krisam@seiko-instruments.de
Website : <http://www.seiko-instruments.de>